

FORESTRY MULCHERS

UML/S

Forestry mulcher for PTO tractors with fixed tooth rotor.

The UML/S is a professional forestry mulcher with a fixed rotor system and a mulching capacity up to 10 in diameter. This unit is ideal for land clearing applications. The frame makes the mulcher more maneuverable when working on steep slopes and in extreme conditions.

This model features the interchangeable Spike counterblades, adjustable skeds and inner anti-wear clades, as standard equipment.



130-190 hp



Ø 10 in max

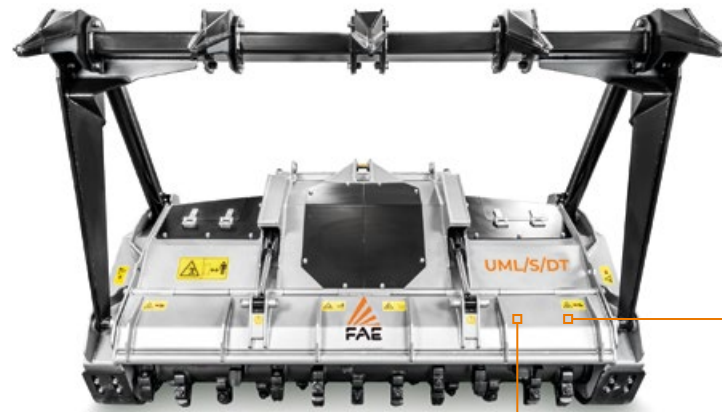

Interchangeable bolted on spike counter blade can adjust final product size while operating



Inner anti wear clad plates FCP absorbs wear while protecting the frame

Z style self ranging system of the PTO drive shaft/gearbox always keeps the correct operating angle between the PTO shaft and the power take-off (optional)

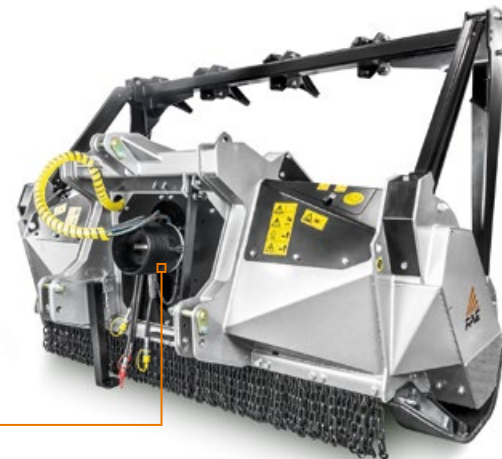

MAIN OPTIONS



Extra ripper for push frame



Special skids to go underground



W style self aligning device between PTO drive shaft/gearbox allows the mulcher to work at several angles without damaging the PTO

STANDARD EQUIPMENT

Hydraulic rear hood	Transmission with belts
Inner anti wear clad plates FCP	Gearbox with freewheel
Enclosed machine body	PTO shaft with cam clutch
Centralized greasing hub	Bolted-on rotor shafts (in forged steel)
Hydraulic hoses integrated in the frame	Interchangeable bolted on spike counter-blade
Cylinder protection	Adjustable skids
Bolted on protection chains	Supporting service leg

OPTIONS

Frontal attachment (UML/S/DT-225)	W style self aligning device between PTO drive shaft/gearbox
Bolt-on chain's protection plates	Special skids to go underground
Multiple tooth options	Mechanical guard frame
Hydraulic top link	Hydraulic guard frame
Z style self ranging system of the PTO drive shaft/gearbox	Extra ripper for guard frame
IVT - CVT or creeper transmission strongly recommended	Forestry tires and carrier belly pan strongly recommended

MODEL	UML/S/DT-200	UML/S/DT-225
Engine (hp)	130-190	130-190
PTO (rpm)	1000	1000
Working width (in)	81	91
Total width (in)	96	105
Weight (lbs)	3726	4023
Rotor diameter (in)	17.7	17.7
Max shredding diameter (in)	10	10
No. teeth type C/3+C/3/SS	42+2	48+4
type I+C/3/SS	60+2	66+2

Data refers to machine as standard set-up. Options may have reflects on weights and dimensions. The technical data in this catalogue may be altered without prior notice.

ROTOR TYPE C



TOOTH C/3 (standard)



TOOTH C/3/HD (option)



BLADE BL (option - requires adaptor)



TOOTH K/3 (option)



TOOTH I (option)



TOOTH C/3/SS (side scraper)

ROTOR TYPE I