

MULTITASKS

SFM

Stone crusher, forestry tiller and mulcher for PTO tractors with fixed tooth rotor.

The SFM is the answer to a very demanding market and tough applications. This unit combines the functionality and efficiency of a forestry mulcher, forestry tiller and rock crusher. The SFM is equipped with interchangeable

bolt-on counter blades, FCP inserts (FAE clade plate) and grill making this machine unique in its category. These options along with FAE's new smoother, more aggressive design differentiate FAE from the rest.



160-300 hp

Ø 8 in max (stones)
Ø 14 in max (trees)
Ø 18 in max (stump)

Depth 12 in

Z style self ranging system of the PTO drive shaft/gearbox helps keep the correct operating angle between the PTO shaft and the power take-off

Hydraulically controlled rear door adjust final product size while machine is working



Forged and hardened interchangeable counter-blades for longest working life

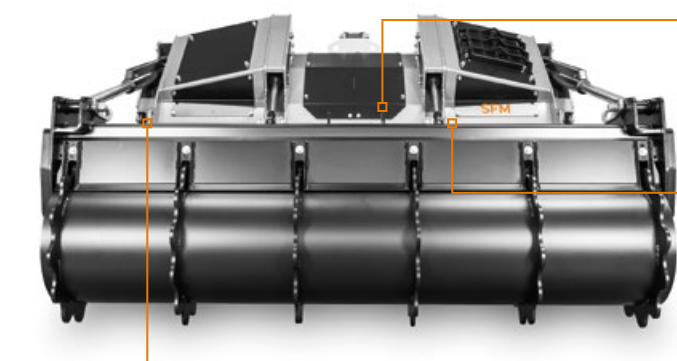

Adjustable extended 3 point linkage fits perfectly with any kind of tractor



Transmission with side gearbox maximize the power delivered to the rotor

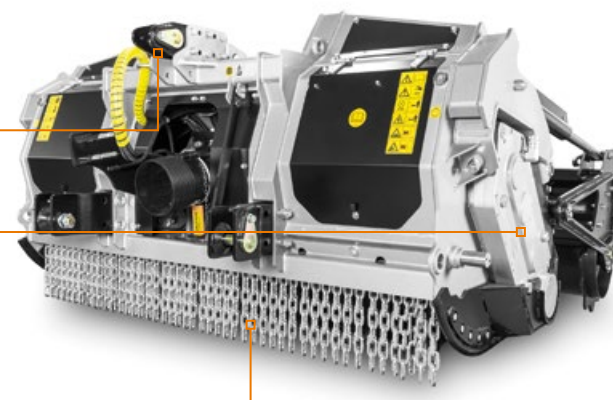

System protection chains the chains are fixed on plate and these plates screwed to the frame



MAIN OPTIONS



W style self aligning device between PTO drive shaft/gearbox allows the machine to work at several angles without damaging the PTO

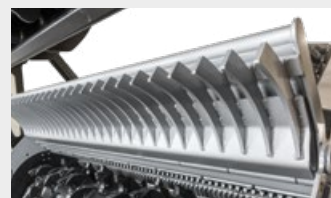

Bolted grid on rear door allows more adjustment of the final material size



Hydraulically adjustable skids allow you to control the rotor depth and prevent material from exiting out the sides



Hydraulic support roller (D. 14 in - D. 20 in) helps with compaction and working uneven terrain

STANDARD EQUIPMENT

Hydraulic rear hood	Side gearbox with oil cooling system
Inner anti wear clad plates FCP	Gearbox with freewheel
Interchangeable inner antiwear plates in Hardox®	Friction clutches
Adjustable extended 3 point linkage	PTO shaft with cam clutch
Transmission with side gearbox	Bolted-on rotor shafts (in forged steel)
Hydraulic hoses integrated in the frame	Hydraulic top link
Cylinder protection	Z style self ranging system of the PTO drive shaft/gearbox
Inside lateral protection	Forged and hardened interchangeable counter-blades
Bolted on protection chains	Adjustable Hardox® counter-blade

OPTIONS

Bolted grid on rear hood	Hydraulically adjustable skids
Bolt-on chain's protection plates	Hydraulic guard frame
High Speed Transmission	Dozing blades
W style self aligning device between PTO drive shaft/gearbox	Hydraulic support roller
IVT - CVT or creeper transmission mandatory	Forestry tires and carrier belly pan strongly recommended

MODEL	SFM-200	SFM-225	SFM-250
Engine (hp)	160-300	170-300	190-300
PTO (rpm)	1000	1000	1000
Working width (in)	81	91	100
Total width (in)	94	104	113
Weight (lbs)	8267	8929	9590
Rotor diameter (in)	26.4	26.4	26.4
Max shredding diameter stones (in)	8	8	8
trees (in)	14	14	14
stump (in)	18	18	18
Max working depth (in)	12	12	12
No. teeth type F/3+STC/3/FP+BAZ	50+6+4	58+6+4	62+6+4

Data refers to machine as standard set-up. Options may have reflects on weights and dimensions. The technical data in this catalogue may be altered without prior notice.



TOOTH F/3 (standard)



TOOTH STC/3/FP (side scraper)



TOOTH BAZ (side scraper)