

NEW
MULTITASKS

SFL

Stone crusher, mulcher and forestry tiller for tractors from 130 hp.

Multitask head for 130 to 220 hp tractors. The SFL can shred wood, shrubs, roots up to 6 inches in diameter, and stumps up to 10 inches in diameter. It can also crush stones up to 4 inches in diameter, operating at depths down to 8 inches. Top features include the adjustable

counter blade, the anti-wear Hardox plates, the hydraulic hood, and the hydraulic support roller (optional). The SFL is available in two widths: SFL-200 and SFL-225, both with dual gear transmission. The head mounts a rotor with K/3 teeth.



- 130-220 hp
- Ø 4 in max (stones)
Ø 6 in max (trees)
Ø 10 in max (stump)
- Depth 8 in

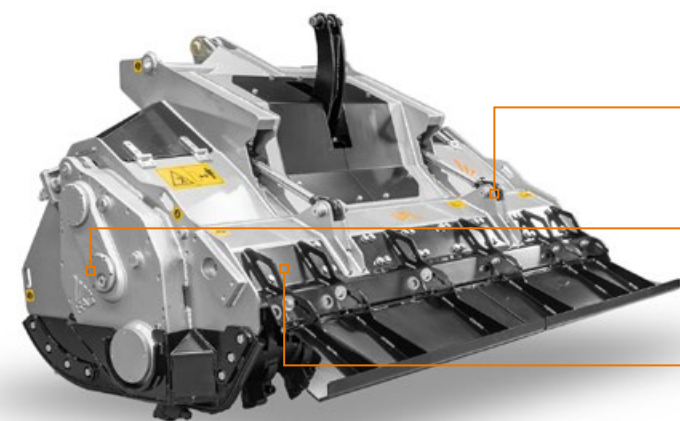

Hydraulically adjustable rear hood

Transmission with side gearbox
maximize the power delivered to the rotor

Interchangeable bolt-on counter blades
for fine mulching and easy maintenance

Bolt-on interchangeable protection chains

Adjustable Hardox® counter blade
to effectively control the final product size

Interchangeable wear-resistant Hardox® plates
for use in extreme conditions and for easier maintenance

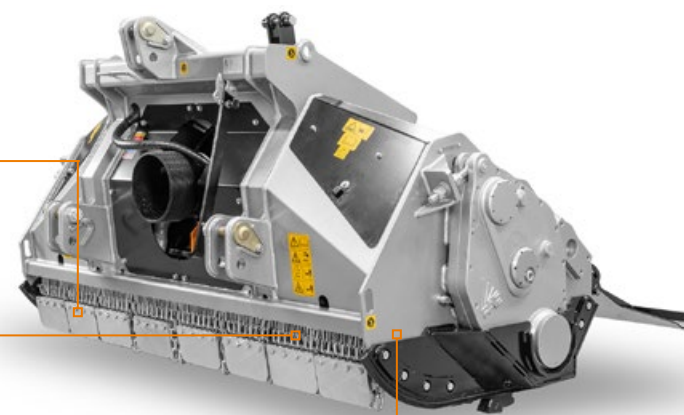

STANDARD EQUIPMENT

| | |
|---|---|
| Hydraulically adjustable rear hood | Central PTO shaft with cam clutch |
| Interchangeable wear-resistant Hardox® plates | Interchangeable forged steel rotor shafts |
| Wear-resistant side plates | Interchangeable bolt-on counter blades |
| Bolt-on interchangeable protection chains | Adjustable Hardox® counter blade |
| Transmission with side gearbox | Skids to go underground |
| Freewheel gearbox | PTO shaft support for machine at rest |
| Side PTO shafts with friction clutches | Rotor with teeth K/3 |

OPTIONS

| | |
|---|---|
| Hood grille | Z style self-aligning system |
| Plates for bolt-on protection chains | W style self-aligning system |
| Central PTO shaft yoke | Dozing blades |
| Hydraulic top link cylinder | Hydraulic support roller |
| IVT - CVT or creeper transmission mandatory | Forestry tires and carrier belly pan strongly recommended |

| MODEL | SFL-200 | SFL-225 |
|------------------------------------|---------|---------|
| Engine (hp) | 130-220 | 130-220 |
| PTO (rpm) | 1000 | 1000 |
| Working width (in) | 82 | 91 |
| Total width (in) | 95 | 104 |
| Weight (lbs) | 5401 | 5732 |
| Rotor diameter (in) | 22 | 22 |
| Max shredding diameter stones (in) | 4 | 4 |
| trees (in) | 6 | 6 |
| stump (in) | 10 | 10 |
| Max working depth (in) | 8 | 8 |
| No. teeth type K/3+C/3/SS+BAZ | 52+6+4 | 58+6+4 |

Data refers to machine as standard set-up. Options may have reflects on weights and dimensions. The technical data in this catalogue may be altered without prior notice.

MAIN OPTIONS



Hood grille



Hydraulic support roller



Z style self-aligning system



W style self-aligning system



TOOTH K/3 (standard)



TOOTH C/3/SS (side scraper)



TOOTH BAZ (side scraper)