

MULTITASKS FOR SPECIAL VEHICLES

SFM/PM

Hydraulic multitask stone crusher, forestry tiller and mulcher.

Extremely sturdy and versatile - the multi-purpose SFM/PM head works with special vehicles up to 450 hp. It crushes stones and shreds logs or stumps up to 12 in deep.



300-450 hp



Ø 8 in max (Stones)
Ø 14 in max (Trees)
Ø 18 in max (Stump)



Depth 12 in



Customized attachment plate (optional)

Hydraulically controlled hood
to adjust final product

Dual transmission with side gearbox
converts RPM to Power

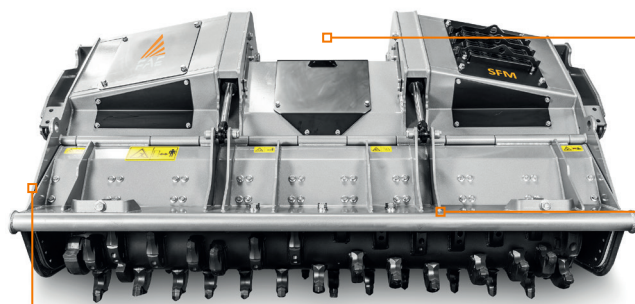

STANDARD EQUIPMENT

Considering the various available options and high level of customization, the final configuration will be specified upon request.

MODEL	SFM/PM-225	SFM/PM-250
Engine (hp)	300-450	300-450
Flow rate (gal/min)	92-103	92-103
Pressure (PSI)	5080-5800	5080-5800
Working width (in)	91	100
Total width (in)	103	113
Weight (lbs)	9039	9700
Rotor diameter (in)	26.4	26.4
Max working depth (in)	12	12
Max shredding diameter		
Stones (in)	8	8
Trees (in)	14	14
Stump (in)	18	18
No. teeth type F/3+STC/3/FP	58+6	62+6

Data refers to machine as standard set-up. Options may have reflects on weights and dimensions. The technical data in this catalogue may be altered without prior notice.



TOOTH F/3
(standard)



TOOTH STC/3/FP
(side scraper)