

FORESTRY TILLERS

SSM

Fixed tooth tiller for medium/high power tractors.

The SSM has been designed and built to be used with medium to high-power tractors (170 to 300 hp). It clears land perfectly, shredding logs up to 50 cm in diameter at a max. depth of 40 cm. SSM also comes in an HP model for tractors up to 300 hp. Both models can be equipped with Standard or Heavy Duty teeth

to work in different soils and ensure the superb performance required to meet different needs. Available options include an adjustable hood grille, a dozing blade and a rear roller for professional results.



170-300 hp

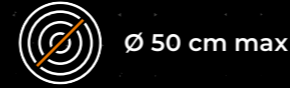

Ø 50 cm max



Depth 40 cm

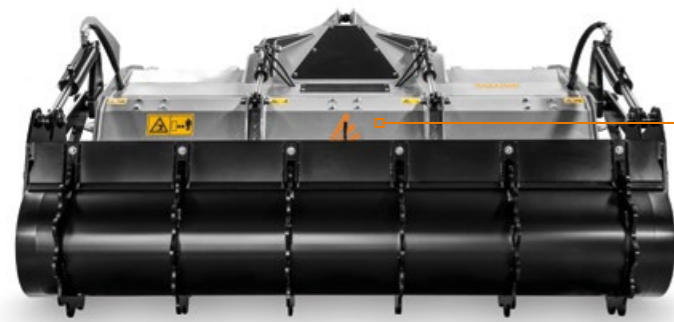

Adjustable Hardox® counter blade

Z style self-aligning system for the PTO drive shaft/gearbox
helps keep the correct operating angle between the PTO shaft and the power take-off

Stronger transmission for tractors up to 300 hp power
(SSM/HP-200, SSM/HP-225 and SSM/HP-250)

Protection chains

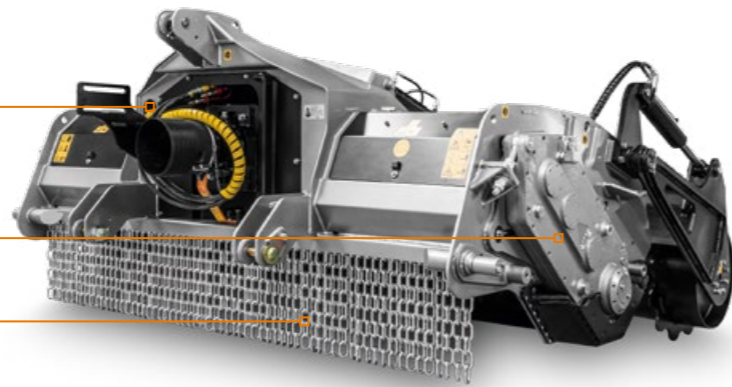

MAIN OPTIONS



W style self aligning device between PTO drive shaft/gearbox
allows the mulcher to work in several angles without damaging the PTO



Hydraulic controlled roller
helps with compaction and working uneven terrain

STANDARD EQUIPMENT

Hydraulically adjustable rear hood	Central PTO shaft with cam clutch
Enclosed, dust-resistant machine body	Interchangeable forged steel rotor shafts
Wear-resistant side plates	Hydraulic top link cylinder
Interchangeable protection chains	Z style self-aligning system
Gear transmission	Adjustable Hardox® counter blade
Freewheel gearbox	PTO shaft support for machine at rest
Side PTO shafts with friction clutches	Side gearbox cooling system (SSM/HP)

OPTIONS

Adjustable hood grille	Dozing blade
Multiple tooth options	Hydraulic support roller
W style self-aligning system	

MODEL	SSM-200	SSM-225	SSM-250	SSM/HP-200	SSM/HP-225	SSM/HP-250
Tractor (hp)	170-250	170-250	170-250	170-300	170-300	170-300
PTO (rpm)	1000	1000	1000	1000	1000	1000
Working width (mm)	2080	2320	2560	2080	2320	2560
Total width (mm)	2410	2650	2890	2410	2650	2890
Weight (kg)	3150	3400	3650	3200	3450	3700
Rotor diameter (mm)	670	670	670	670	670	670
Max shredding diameter (mm)	500	500	500	500	500	500
Max working depth (mm)	400	400	400	400	400	400
No. teeth type A/3+MH/3	76+4	88+4	102+4	76+4	88+4	102+4

Data refers to machine as standard. The technical data in this catalogue may be altered without prior notice.

ROTOR TYPE A



TOOTH A/3
(standard)

TOOTH A/3/HD
(option)

TOOTH F/3
(option)

TOOTH MH/3
(side scraper)