

STONE CRUSHERS

RSL

Stone crusher for PTO tractors with fixed teeth rotor.

The RSL is a multifunction head that enables crushing of stones and milling of slabs of rock, to a depth of 28 cm. The compact size, low weight and minimum operating width of 100 cm make it perfect in limited spaces. The gear transmission enables operation with

constantly optimal levels of torque and power. The dedicated teeth guarantee optimal results in the presence of stones and slabs of rock. The crushing chamber is protected by Hardox coatings to offer maximum wear resistance even in the most demanding conditions.

 80-190 hp

 Ø 30 cm max (stones)

 Depth 28 cm

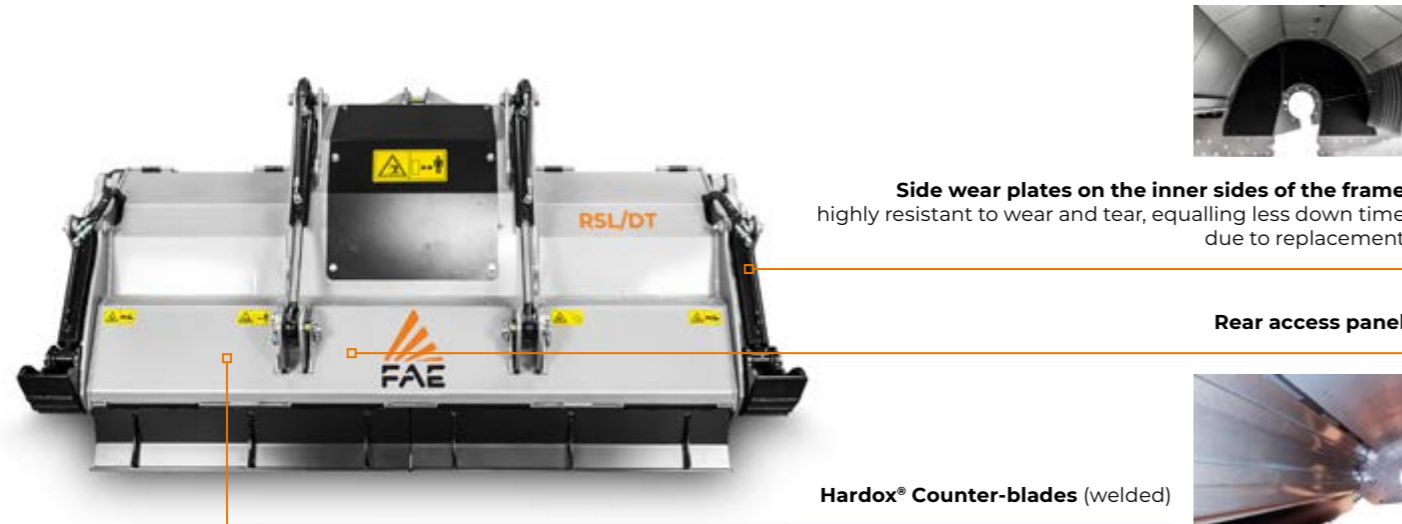

Rear grid
the grid on the rear door helps define the size of the output materials.



Hardox® steel - Wear plates
these allow the machine to resist wear and tear and can be easily replaced as needed

MAIN OPTIONS



Hydraulic top link



Bolt-on chain's protection plates



Multiple tooth options



The **Water Spray System** (Basic & High Flow) cools the teeth to help them last longer

STANDARD EQUIPMENT

Hydraulic rear hood	Gearbox with freewheel
Interchangeable inner antiwear plates in Hardox®	Friction clutches (RSL/DT)
Enclosed machine body	PTO shaft with cam clutch
Bolted grid on rear hood	Bolted-on rotor shafts (in forged steel)
Inside lateral protection	Flat pressed welded steel counter-blades
Protection chains	Hydraulically adjustable skids
Transmission with side gearbox	Dozing blades

OPTIONS

Bolt-on chain's protection plates	Water spray system WSS Basic
Multiple tooth options	Water spray system WSS High Flow (RSL/DT)
Hydraulic top link	Extended 3 point linkage (RSL)

MODEL	RSL-100	RSL-125	RSL-150	RSL/DT-175	RSL/DT-200	RSL/DT-225
Tractor (hp)	80-120	90-120	100-120	120-190	130-190	140-190
PTO (rpm)	540	540	540	1000	1000	1000
Working width (mm)	1000	1240	1480	1720	1960	2200
Total width (mm)	1410	1650	1890	2130	2370	2610
Weight (Kg)	1600	1800	1960	2350	2500	2650
Max shredding diameter (mm)	300	300	300	300	300	300
Working depth (mm) (Max. 1-Max. 2)	150-280	150-280	150-280	150-280	150-280	150-280
ROTOR G/3						
No. teeth type G/3+STC/3/FP	28+6	36+6	42+6	50+6	60+6	70+6
Rotor diameter (mm)	595	595	595	595	595	595
Working depth (mm) (Max. 1-Max. 2)	160-280	160-280	160-280	160-280	160-280	160-280
ROTOR R						
No. picks type R/65+R/65/HD	58+16	74 +16	98+16	122+16	138+16	154+16
Rotor diameter (mm)	612	612	612	612	612	612

Max. 1: with rotor only **Max. 2:** maximum depth (maximum working depth depending on ground conditions).
This information refers to the machine equipped as standard. The technical data in this catalogue may be altered without prior notice.

ROTOR TYPE G



TOOTH G/3 (standard)



TOOTH G/3/HD (option)



ADAPTOR G/3 WITH PICK R/44 (option)

ROTOR TYPE R



PICK R/65 (standard)



PICK R/65/HD (option)



ADAPTOR R/65 WITH PICK R/44 (option)



TOOTH STC/3/FP (side scraper)



PICK R/65/HD (side scraper)