

MULTITASKS FOR SPECIAL VEHICLES

SFH/PM

Hydraulic multitask stone crusher, forestry tiller and mulcher.

The SFH/PM head works with special vehicles up to 450 hp. It shreds logs or stumps and crushes stones up to 40 cm deep. Its double-gear transmission increases shredding power.



350-450 hp



Ø 35 cm max (Stones)

Ø 45 cm max (Trees)

Ø 55 cm max (Stump)



Depth 40 cm

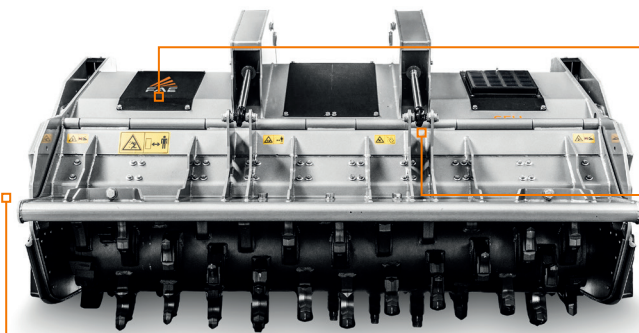

Customized attachment plate (optional)

Hydraulically controlled hood to adjust final product

Dual transmission with side gearbox converts RPM to Power

STANDARD EQUIPMENT

Considering the various available options and high level of customization, the final configuration will be specified upon request.

MODEL	SFH/PM-225	SFH/PM-250
Engine (hp)	350-450	350-450
Flow rate (L/min)	470-530	470-530
Pressure (bar)	350-415	350-415
Working width (mm)	2320	2560
Total width (mm)	2710	2950
Weight (kg)	5600	5900
Rotor diameter (mm)	900	900
Max working depth (mm)	400	400
Max shredding diameter	Stones (mm)	350
	Trees (mm)	450
	Stump (mm)	550
No. teeth type G/3+STC/FP+STC/3/FP	60+4+6	66+4+6

Data refers to machine as standard. The technical data in this catalogue may be altered without prior notice.

ROTOR TYPE G



TOOTH G/3 (standard)



TOOTH G/3/HD (option)



TOOTH STC/3/FP (side scraper)



TOOTH STC/FP (side scraper)