

## FORESTRY MULCHERS

# UMM

### Forestry mulcher for PTO tractors with fixed tooth rotor.

The UMM is a professional forestry mulcher with a fixed rotor system and a mulching capacity up to 30 cm in diameter. This unit is ideal for heavy land clearing applications. The frame has been completely redesigned and it makes the mulcher more maneuverable when working on steep slopes and in extreme conditions.

This model features the new counterblade Spike PRO as standard equipment, and features the new hydrodynamic joints as an option. The UMM also features interchangeable antiwear plates in Hardox® steel, new centralized greasing system and guide frame with Ripper guide pins.



160-240 hp



Ø 30 cm max

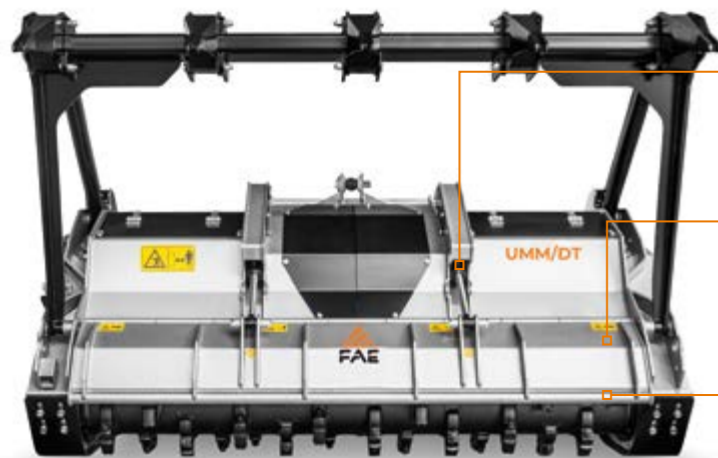

**Cylinder protection**  
to prevent cylinder damage

**Reinforced hydraulic hood**  
helps provide a finer product while being more durable

**Forged and hardened interchangeable counter-blades**  
for the longest working life while providing a finer product



**Z style self ranging system of the PTO drive shaft/gearbox**  
helps keep the correct operating angle between the PTO shaft and the power take-off

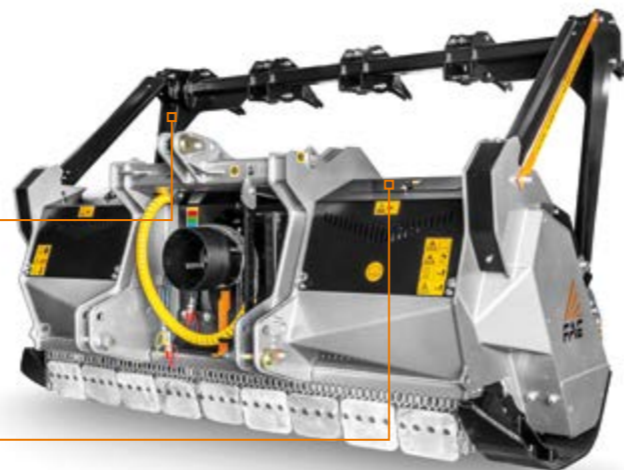

**Centralized greasing hub**  
allows easy maintenance

### MAIN OPTIONS



**W style self-aligning device between PTO drive shaft/gearbox**  
allows the mulcher to work in several angles without damaging the PTO



**Standard hydraulic clutch transmission**  
protects the transmission at PTO engagement for smooth starting and improves machine performance



**Mechanical/hydraulic push frame**  
guides and pushes material away from carrier



**Additional ripper for push frame**  
helps with the positioning of standing material while mulching

### STANDARD EQUIPMENT

Hydraulic rear hood	Gearbox with freewheel
Enclosed machine body	PTO shaft with cam clutch
Centralized greasing hub	Bolted-on rotor shafts (in forged steel)
Hydraulic hoses integrated in the frame	Hydraulic top link
Cylinder protection	Z style self ranging system of the PTO drive shaft/gearbox
Dual row protection chains	Interchangeable bolted on spike PRO counter-blade
Transmission with belts	Adjustable skids
Supporting service leg	

### OPTIONS

Bolt-on chain's protection plates	Special skids to go underground
Hydraulic clutch transmission	Mechanical guard frame
Multiple tooth options	Hydraulic guard frame
W style self-aligning device between PTO drive shaft/gearbox	Extra ripper for guard frame

MODEL	UMM/DT-200	UMM/DT-225	UMM/DT-250
<b>Tractor</b> (hp)	160-240	170-240	180-240
<b>PTO</b> (rpm)	1000	1000	1000
<b>Working width</b> (mm)	2070	2310	2550
<b>Total width</b> (mm)	2464	2704	2944
<b>Weight</b> (kg)	2230	2480	2550
<b>Rotor diameter</b> (mm)	500	500	500
<b>Max shredding diameter</b> (mm)	300	300	300
<b>No. teeth</b> type C/3+C/3/SS	42+2	46+2	52+2
type I+C/3/SS	68+2	78+2	86+2

Data refers to machine as standard. The technical data in this catalogue may be altered without prior notice.

### ROTOR TYPE C



**TOOTH C/3**  
(standard)



**TOOTH C/3/HD**  
(option)



**BLADE BL**  
(option - requires adaptor)



**TOOTH K/3**  
(option)

### ROTOR TYPE I



**TOOTH I**  
(option)



**TOOTH C/3/SS**  
(side scraper)